

CASE STUDY



The nation's largest electrical and gas utility, operating the largest fleet of nuclear generating stations in the nation, and the third largest fleet in the world, selects Doerfer's Spent Fuel Handling System including Wheelift transporters for movement of fuel casks within their Independent Spent Fuel Storage Installation (ISFSI)

Challenge: Provide an integrated system for the handling, transportation, and loading of spent fuel transport casks into existing Horizontal Storage Modules (HSM).

Solution: Doerfer's weatherized diesel powered twelve axle 240-ton Omni-directional Transporter de-rated to 135 ton for soft surface travel with an infinitely variable travel speed up to 120 FPM, 10" vertical lift, and 6% (3.44°) automatic tilt correction working in conjunction with Doerfer's autonomous skid fixturing system.

Benefit:

- Allows ISFSI expansions to be designed comfortable with 36' aisles vs. 60' aisles
- Reduces labor. Reduces move schedule. Simplifies cask alignment and shortens exposure time minimizing risk opportunities.
- Allows travel over existing paved roadways
- Provides significant reliability improvements over existing processes and equipment
- Provides turnkey system responsibility for lay-down, transportation and HSM loading

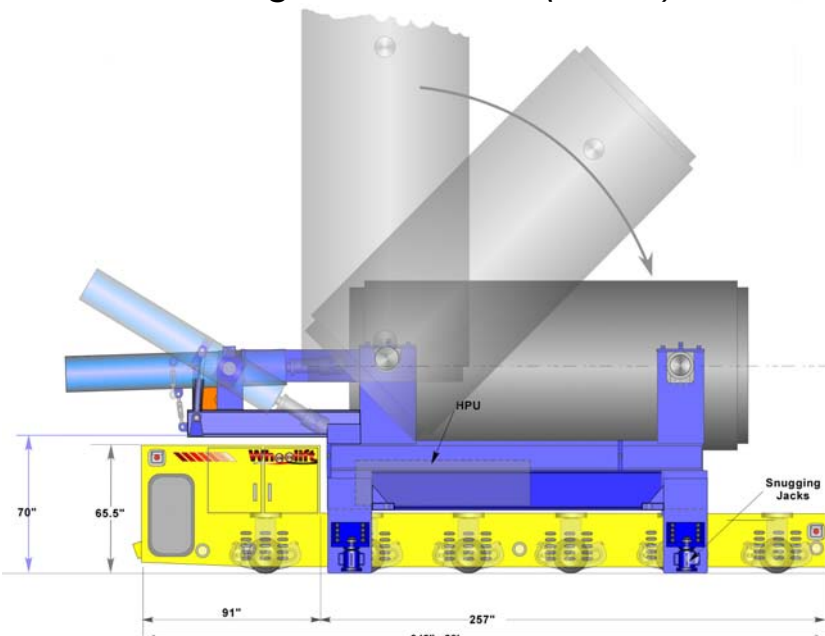

Wheelift

A Doerfer Companies' Technology



For nuclear plants that are using, or intend to use the NUHOMS[®] system for spent fuel storage, a new self-propelled transporter technology has emerged that dramatically improves the movement of spent fuel into ISFSI facilities. These new all-directional travel transporters maneuver well in much smaller spaces, allowing the horizontal storage modules (HSM) to be closer together. The wide alleys that are necessary today for maneuvering trailer-mounted transfer cask skids can be made much narrower in new facilities in order to gain much needed additional storage space. In this case, when the transporter carried cask transfer skid approaches an alley that runs between storage modules, rather than turn into the alley, the transporter can simply stop and rotate its axles 90° and drive sideways down the alley. With sideways adjustment confirmed, all of the axles return to forward travel. Horizontal pitch to reach exact level travel is also simply a fingertip control function of the transporter's independent suspension. The operator has precise control in adjusting tilt fore and aft to reach exact vertical and level alignment. Once final alignment is optically confirmed, four "snugging" jacks engage assuring that the alignment remains solid through the payload transfer. The cask transfer will take place with



Doerfer's gas operated integrated grapple in lieu of the industry's standard hydraulic offering, eliminating all possibilities of hydraulic oil contamination in event of a line rupture. With the transfer completed, the ram will withdraw, the snagging jacks will be reversed, and the transporter will back away to go on to its next mission.

A critical requirement was to have the ability to travel over the existing paved roadway up to the ISFSI. Doerfer's load sharing Wheelift technology is the enabler for this need. The on-center axles have interconnecting fluid lines that divide them into load sharing groups to assure that every wheel carries only its specific share of the load, regardless of slopes and irregularities in the road surfaces.

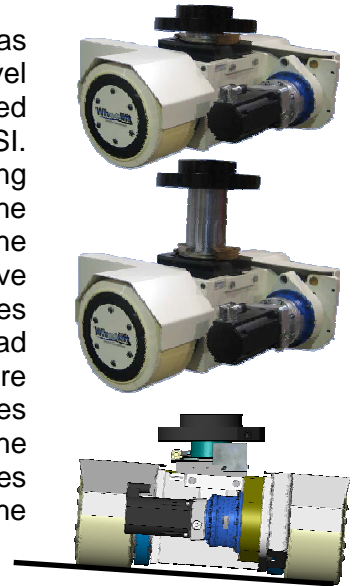

Wheelift Transporters and AGVs are manufactured in central Iowa custom engineered to application specific requirements. Chassis and fixtures are available with load capacities to 500+ tons and deck heights as low as 18". Power options include diesel, LP gas, battery, or umbilical cord. Computerized all electric omni-directional drives are standard with individual axle ratings of 15, 20, or 25-ton.

Wheelift™ is a Doerfer Companies technology. Doerfer engineers and builds application specific manufacturing machinery and systems. Operating from four North American locations with over 700,000 sq. ft. and 800+ employees, Doerfer offers expanded technical and manufacturing resources, is NQA-1 certified, and follows ISO 9001 standards.

For more information on our Wheelift Transporters and AGV systems capabilities, please visit us at www.wheelift.com or email roy.linden@doerfer.com

"NUHOMS" is the registered trademark of Transnuclear Division of AREVA.